



## XX Ultrasonic Sensors for mobile equipment, material handling & conveying



### Groundbreaking software-configurable ultrasonic sensors to detect virtually any object

The new range of XX Ultrasonic Sensors offers a wide variety of sensing distances, outputs and operating modes to provide the flexibility and capabilities required for demanding industrial applications. These sensors can be easily configured with the push of a button or with our new configuration software for more advanced settings.

#### Detection of small targets and curved surfaces

A powerful transducer and superior electronic design have made it easy for the new XX Ultrasonic Sensors to detect small objects. The built-in high sensitivity level also enables them to detect many poorly reflective and curved surfaces.

#### Detection over a large coverage area

In the past, attempts to detect objects over a large area with multiple ultrasonic sensors would sometimes fail due to the fact that the sensor signals interfered with each other. With the XX Ultrasonic Sensors' 'synchronization' feature, it is now possible to reliably detect objects over a large area with minimal risk of cross-talk, even when the sensors are installed closer together.

#### Highly immune to electromagnetic interference

The new XX Ultrasonic Sensors are E2-certified for mobile equipment. This entails a higher immunity to electromagnetic interference even in the most demanding environments.

Simply easy!



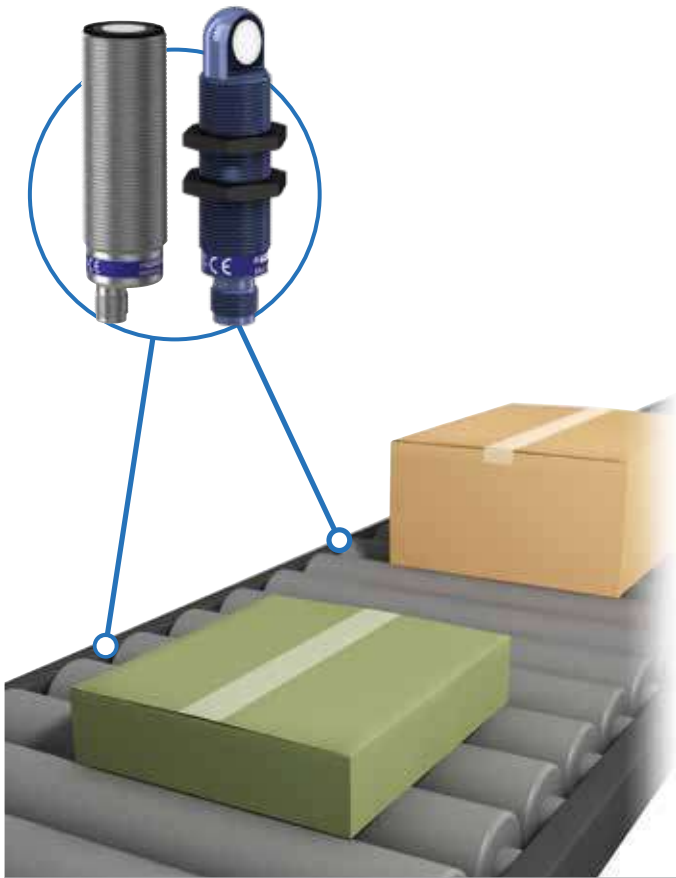

## Features and Benefits

### Standard format

- M18 & M30 cylindrical: straight & 90° angled (select models)
- M12, 5-pin connector
- Available in plastic, Nickel-plated brass & SS316L

### High performance

- High tilt angle of +/- 35° or more at 50% sensing distance for detecting objects with irregular positioning
- Detect Ø1mm cylinders up to 600mm
- Synchronization of up to 8 sensors and multiplexing features for improved flexibility

### Easy configuration using XX Configuration Software or XXZPB100 remote accessory for 1, 2, & 4m; (8m version features integrated pushbutton)

- Analog output function: Select between Direct or Inverse
- Digital output: Select between NO/NC and Window / Reflex / Proximity / Pump modes
- Easy live monitoring and troubleshooting available when using XX Configuration Software

## Characteristics

- Operating temperature: -25°...70°C
- Certifications: CE, cULus, RCM, EAC, and E2
- Degree of protection: IP67

## Part Numbers

Body style	Sn	Output	Plastic	Ni-Plated Brass	Stainless Steel
Ø18	1m	Digital; PNP, NO/NC	XXS18P1PM12	XXS18B1PM12	XXS18S1PM12
		Analog; 4...20 mA	XXS18P1AM12	XXS18B1AM12	XXS18S1AM12
		Analog; 0...10 V	XXS18P1VM12	XXS18B1VM12	XXS18S1VM12
Ø30	1m	Digital; PNP, NO/NC	XXS30P1PM12*	XXS30B1PM12	XXS30S1PM12
		Analog; 4...20 mA	XXS30P1AM12*	XXS30B1AM12	XXS30S1AM12
		Analog; 0...10 V	XXS30P1VM12*	XXS30B1VM12	XXS30S1VM12
	2m	Digital; PNP, NO/NC	XXS30P2PM12	XXS30B2PM12	XXS30S2PM12
		Analog; 4...20 mA	XXS30P2AM12	XXS30B2AM12	XXS30S2AM12
		Analog; 0...10 V	XXS30P2VM12	XXS30B2VM12	XXS30S2VM12
	4m	Digital; PNP, NO/NC	XXS30P4PM12	XXS30B4PM12	XXS30S4PM12
		Analog; 4...20 mA	XXS30P4AM12	XXS30B4AM12	XXS30S4AM12
		Analog; 0...10 V	XXS30P4VM12	XXS30B4VM12	XXS30S4VM12

Part numbers above are for straight versions. 1 and 2 meter products are available in 90° angled versions; just change the first "S" of the part number to an "A" (for example, **XXS18P1PM12** becomes **XXA18P1PM12**). \*51mm short body version.



### XX Configuration Software (XXZKIT01)

For an easy way to configure advanced / custom sensor settings, XX Configuration software is now available. Contact your local Telemecanique Sensors sales representative for more details.

For our complete selection of sensor solutions, visit [www.tesensors.com](http://www.tesensors.com)

Schneider Electric Industries SAS  
 Head Office  
 35, rue Joseph Monier – CS 30323  
 F92506 Rueil-Malmaison Cedex  
 FRANCE  
[www.tesensors.com](http://www.tesensors.com)

Due to the constant evolution of standards and equipment, the specifications indicated in the text and images of this document can only be guaranteed after confirmation by our departments. Print: Schneider Electric Photos: Schneider Electric

©2019 Schneider Electric. All Rights Reserved. Schneider Electric, OsiSense, and Telemecanique are trademarks and the property of Schneider Electric SE, its subsidiaries and affiliated companies. All other trademarks are the property of their respective owners.

07/2019 9006HO1902